

Suspension Industrielle LED FLEXLINE

Suspension Industrielle LED FLEXLINE - 9 EN 1 - 100W - ZHAGA Sensor Ready - DeliTech®



IP 65

GARANTIE
5 ANS

60W 80W 100W

Z H A G A
Consortium

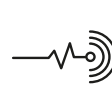

Accessoires disponibles :

Les suspensions Industrielles LED FLEXLINE sont compatibles avec des détecteurs de présence. Il est possible de fixer des lentilles optiques afin de modifier la diffusion la lumière afin d'obtenir des angles de 60°, 90° et 120°. Enfin, les suspensions Industrielles LED FLEXLINE peuvent être contrôlées à distance grâce à notre application DELISMART.



Référence	Puissance	Lumens	Température de couleur	Angle de diffusion	Dimensions	Indice de Protection	Alimentation
DTSL1-HB100W01-60	100W	170 lm/W	2700K - 6500K	60°	Ø 260 x 146 mm	IP 65	100 - 277V AC
DTSL1-HB100W01-90	100W	170 lm/W	2700K - 6500K	90°	Ø 260 x 146 mm	IP 65	100 - 277V AC
DTSL1-HB100W01-120	100W	170 lm/W	2700K - 6500K	120°	Ø 260 x 146 mm	IP 65	100 - 277V AC

Puissance modifiable

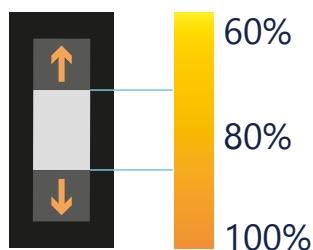

CCT modifiable

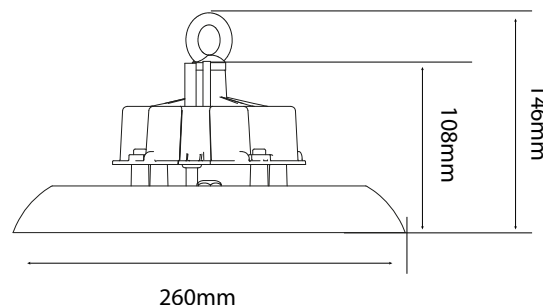
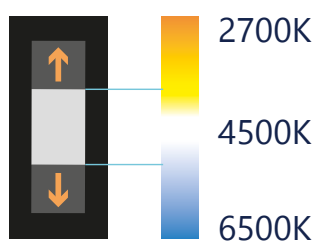

Diffusion de la lumière

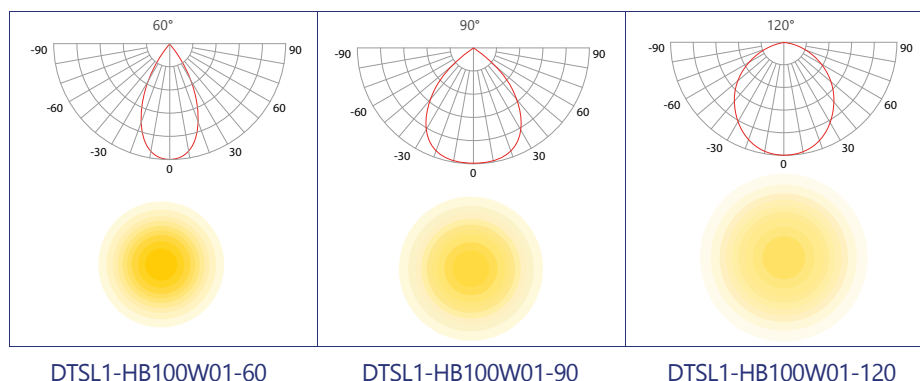

DTSL1-HB100W01-60

DTSL1-HB100W01-90

DTSL1-HB100W01-120

100-277
V AC

IP 65

L80B10

IRC>80

1-10V

ERP

